

The Quantum Theory in Decision Making

Dionysios P. Kalogeras¹

Abstract

Humans do not always make the most rational decisions. As studies have shown, even when logic and reasoning point in one direction, sometimes humans “walk” to the opposite route, motivated by personal bias or simply "wishful thinking." This paradoxical human behavior has resisted explanation by classical decision theory for over a decade. Scientists have shown that a quantum probability model can provide a simple explanation for human decision-making. In military, decision-making process is considered to be the most neuralgic one. With the recent interest in quantum computing and quantum information theory, there has been an effort to recast classical game theory using quantum probability amplitudes, and hence study the effect of quantum superposition, interference and entanglement on the agents’ optimal strategies. Apart from unsolved problems in quantum information theory, quantum game theory and decision –making, may be useful in studying quantum communication since that can be considered as a game where the objective is to maximize effective communication. This paper discusses the idea of using quantum theory to decision making.

¹ HellemicArmy 14, Kanigos Str., Piraeus 18534, Greece.
E-mail: dionkaloger@yahoo.gr

Keywords: Quantum theory, game theory, decision making

1 Introduction

The classical theory of decision making is based on the relevant theory formalized by Von Neumann and Morgenstern ([1] and [2]). In spite of its normative appeal, since then, many researchers have discovered many systematic violations of expected utility theory especially in experiments involving real human beings. Some well known works are the one of Allais ([2]), Edwards ([3]) and Ellsberg ([4]). The most significant conclusion of all these works is the verification that human beings' decision does not meet the principles of the classical decision making principles rather than paradoxes.

This paper presents, by a literature point of view, the co-said "Quantum decision theory". The roots of the aforementioned theory are found in quantum theory; In this frame this work is trying to show how the strict mathematical structure of quantum mechanics can provide a general description of quantum measurements and of quantum information processing ([1,7,8,9,10]).

In order to achieve this purpose, the following methodology is developing into ontological parts. In the first part the fundamentals of the game theory are presented; In the second one the basics of the quantum theory are also presented; in the third part the literature review of the works associated with the decision making by using quantum theory are noted. Finally some useful examples are outlined in order reader can understand the precise nature of the engagement. Conclusions and future research are closing this paper.

2 The Decision Making Theory (or Gaming Theory)

Decision theory is theory concerning decisions. The subject is not considered to be a very unified one. To the contrary, there are many different ways to theorize about decisions, and therefore also many different research traditions. Instead, the starting-point of the modern discussion is generally taken to be John Dewey's ([1910] 1978, pp. 234-241) exposition of the stages of problem-solving. According to Dewey, problem-solving consists of five consecutive stages:

- (1) a felt difficulty,
- (2) the definition of the character of that difficulty,
- (3) suggestion of possible solutions,
- (4) evaluation of the suggestion, and
- (5) further observation and experiment leading to acceptance or rejection of the suggestion.

Game theory attempts to mathematically model a situation where agents interact. The agents in the game are called players, their possible actions moves, and a prescription that specifies the particular move to be made in all possible game situations a strategy ([9]). That is, a strategy represents a plan of action that contains all the contingencies that can possibly arise within the rules of the game. In response to some particular game situation, a pure strategy consists of always playing a given move, while a strategy that utilizes a randomizing device to select between different moves is known as a mixed strategy ([9] and [8]).

The utility to a player of a game outcome is a numerical measure of the desirability of that outcome for the player. A payoff matrix gives numerical values to the players' utility for all the game outcomes. It is assumed that the players will seek to maximize their utility within the given rules of the game. Games in which the choices of the players are known as soon as they are made are called games of perfect information. A dominant strategy is one that does at least as well as any competing strategy against any possible moves by the other player(s). The Nash equilibrium (NE) is the most important of the possible equilibria in game theory. It

is the combination of strategies from which no player can improve his/her payoff by a unilateral change of strategy. A Pareto optimal outcome is one from which no player can obtain a higher utility without reducing the utility of another. Strategy A is evolutionary stable against B if, for all sufficiently small, positive q , A performs better than B against the mixed strategy $(1 - q)A + qB$. An evolutionary stable strategy (ESS) ([36]) is one that is evolutionary stable against all other strategies. The set of all strategies that are ESS is a subset of the NE of the game. A two player zero-sum game is one where the interests of the players are diametrically opposed. That is, the sum of the payoffs for any game result is zero. In such a game a saddle point is an entry in the payoff matrix for (say) the row player that is both the minimum of its row and the maximum of its column ([9]).

2.1 The known prisoner dilemma

A two player game where each player has two possible moves is known as a 2×2 game, with obvious generalizations to larger strategic spaces or number of players. As an example, consider one such game that has deservedly received much attention: the prisoners' dilemma. Here the players' moves are known as cooperation (C) or defection (D). The payoff matrix is such that there is a conflict between the NE and the Pareto optimal outcome. The payoff matrix can be written as

	Bob (C)	Bob (D)
Alice : C	(3, 3)	(0, 5)
Alice : D	(5, 0)	(1, 1)

where the numbers in parentheses represent the row (Alice) and column (Bob) player's payoffs, respectively. The game is symmetric and there is a dominant strategy, that of always defecting, since it gives a better payoff if the other player

cooperates (five instead of three) or if the other player defects (one instead of zero). Where both players have a dominant strategy this combination is the NE. The NE outcome {D, D} is not such a good one for the players, however, since if they had both cooperated they would have both received a payoff of three, the Pareto optimal result. In the absence of communication or negotiation we have a dilemma, some form of which is responsible for much of the misery and conflict through out the world.

3 The quantum theory

Quantum mechanics departs from classical mechanics primarily at the quantum realm of atomic and subatomic length scales. Quantum mechanics provides a mathematical description of much of the dual particle-like and wave-like behavior and interactions of energy and matter. In advanced topics of quantum mechanics, some of these behaviors are macroscopic and only emerge at extreme (i.e., very low or very high) energies or temperatures. The name quantum mechanics derives from the observation that some physical quantities can change only in discrete amounts (Latin *quanta*), and not in a continuous (cf. *analog*) way. For example, the angular momentum of an electron bound to an atom or molecule is quantized. In the context of quantum mechanics, the wave–particle duality of energy and matter and the uncertainty principle provide a unified view of the behavior of photons, electrons, and other atomic-scale objects.

$$i\hbar \frac{\partial \Psi}{\partial t} = \hat{H}\Psi \text{ :time-dependent Schrödinger equation (general)}$$

$$E\Psi = \hat{H}\Psi \text{ :time-independent Schrödinger equation (general)}$$

The simplest equation expression for a quantum particle prisoned in a box is presented in the following one.

$$-\frac{\hbar^2}{2m} \frac{d^2\psi}{dx^2} = E\psi.$$

The probabilistic nature of quantum mechanics thus stems from the act of measurement. This is one of the most difficult aspects of quantum systems to understand. It was the central topic in the famous Bohr-Einstein debates, in which the two scientists attempted to clarify these fundamental principles by way of thought experiments. In the decades after the formulation of quantum mechanics, the question of what constitutes a "measurement" has been extensively studied. Newer interpretations of quantum mechanics have been formulated that do away with the idea of "wavefunction collapse" (see, for example, the relative state interpretation). The basic idea is that when a quantum system interacts with a measuring apparatus, their respective wavefunctions become entangled, so that the original quantum system ceases to exist as an independent entity. For details, see the article on measurement in quantum mechanics ([9]).

Since its inception, the many counter-intuitive aspects and results of quantum mechanics have provoked strong philosophical debates and many interpretations. Even fundamental issues, such as Max Born's basic rules concerning probability amplitudes and probability distributions took decades to be appreciated by society and many leading scientists. Indeed, the renowned physicist Richard Feynman once said, "I think I can safely say that nobody understands quantum mechanics."([10])

The Copenhagen interpretation - due largely to the Danish theoretical physicist Niels Bohr - remains the quantum mechanical formalism that is currently most widely accepted amongst physicists, some 75 years after its enunciation. According to this interpretation, the probabilistic nature of quantum mechanics is not a temporary feature which will eventually be replaced by a deterministic theory, but instead must be considered a final renunciation of the classical idea of "causality". It is also believed therein that any well-defined application of the quantum mechanical formalism must always make reference to the experimental arrangement, due to the complementarity nature of evidence obtained under different experimental situations.

4 Decision Theory Anomaly's Indications

A very well known example having indications about a non rational way of deciding is the one given by researchers (Physics.org). In this example it is said that if you were asked to gamble in a game in which you had a 50/50 chance to win \$200 or lose \$100, would you play? Moreover in the referred study, participants were told that they had just played this game, and then were asked to choose whether to try the same gamble again. One-third of the participants were told that they had won the first game, one-third were told they had lost the first game, and the remaining one-third did not know the outcome of their first game. Most of the participants in the first two scenarios chose to play again (69% and 59%, respectively), while most of the participants in the third scenario chose not to (only 36% played again). These results violate the “sure thing principle,” which says that if you prefer choice A in two complementary known states (e.g., known winning and known losing), then you should also prefer choice A when the state is unknown. So why do people choose differently when confronted with an unknown state?

Suppose you receive the following questionnaire in an email:

Imagine an urn containing 90 balls of three different colors: red balls, black balls and yellow balls. We know that the number of red balls is 30 and that the sum of the black balls and the yellow balls is 60. Our questions are about the situation where somebody randomly takes one ball from the urn (MIT Review , 2012).

- The first question is about a choice between two bets: Bet I and Bet II. Bet I involves winning '10 euros when the ball is red' and 'zero euros when it is black or yellow'. Bet II involves winning '10 euros when the ball is black' and 'zero euros when it is red or yellow'. The first question is: Which of the two bets, Bet I or Bet II, would you prefer?
- The second question is again about a choice between two different bets, Bet III and Bet IV. Bet III involves winning '10 euros when the ball is red

or yellow' and 'zero euros when the ball is black'. Bet IV involves winning '10 euros when the ball is black or yellow' and 'zero euros when the ball is red'.

The second question is: which of the two bets, Bet III or Bet IV, would you prefer?

This are exactly the questions sent out by Diederik Aerts and pals at the Brussels Free University in Belgium. They received replies from 59 people which broke down like this: 34 respondents preferred Bets I and IV, 12 preferred Bets II and III, 7 preferred Bets II and IV and 6 preferred Bets I and III. That most respondents preferred Bets I and IV is no surprise. It's been verified in countless experiments since the 1960s when the situation was dreamt up by Daniel Ellsberg, a Harvard economist (who more famously leaked the Pentagon Papers later that decade). The situation is interesting because, paradoxically, a branch of science called decision theory, on which modern economics is based, predicts that humans ought to make an entirely different choice.

Here's why. Decision theory assumes that any individual tackling this problem would do it by assigning a fixed probability to the chance of picking a yellow or black ball and then stick with that probability as they chose their bets. This approach leads to the conclusion that if you prefer Bet I, then you must also prefer Bet III. But if you prefer Bet II, then you must also prefer Bet IV.

Of course, humans don't generally think like that, which is why most people prefer Bets I and IV (and why modern economic theory has served us so badly in recent years). At the heart of the Ellsberg paradox are two different kinds of uncertainties. The first is a probability: the chance of picking a red ball versus picking a non-red ball, which we are told is $1/3$. The second is an ambiguity: the chance of the non-red ball being black or yellow which is entirely uncertain. Conventional decision theory cannot easily handle both types of uncertainty. But various researchers in recent years have pointed out that quantum theory can cope

with both types and what's more, can accurately model the patterns of answers that humans come up with.

We looked at an example a couple of years ago that showed how quantum probability theory can explain other paradoxical behaviors in humans called the conjunction and disjunction fallacies. Now Aerts and pals have done the same for the Ellsberg paradox by creating a model of the way humans think about this problem and framing it in terms of quantum probability theory. In fact, these guys go further. They point out that humans can also think in a way that is consistent with decision theory and therefore that this thinking must employ classical logic. So both classical and quantum logic must both be at work at some level in human thought.

Maybe. The big surprise is that quantum theory works at all. Just why quantum probability theory should explain the strange workings of the human mind, nobody is quite sure. Neither is it yet clear how quantum probability theory will help to mould new ideas about economics and broader human behavior. But that's why there is so much excitement over this new approach and why you're likely to hear much more about it in future.

Linda is 31 years old, single, outspoken, and very bright. She majored in philosophy. As a student, she was deeply concerned with issues of discrimination and social justice, and also participated in antinuclear demonstrations.

Which is more probable?

- Linda is a bank teller.
- Linda is a bank teller and is active in the feminist movement.

It turns out that 85 per cent of people choose the second option. But the probability of two events occurring together (in conjunction) is always less than or equal to the probability of one of them alone.

This is the conjunction fallacy (humans show a similar problem over the probability of one event OR another being true, called the disjunction fallacy). The question is how to explain the problem humans have with this kind of reasoning.

Until now, psychologists have turned to classical probability theory to study the concept of probability judgment error. This allows them to build a mathematical model of human reasoning that allows for errors in judgment. But Jerome Busemeyer at Indiana University and buddies have a different take. They say that quantum probability theory leads to more realistic predictions about the type of errors humans make. “Quantum probability theory is a general and coherent theory based on a set of (von Neumann) axioms which relax some of the constraints underlying classic (Kolmogorov) probability theory,” say the team.

That’s an interesting insight, to say the least. And if it pans out, it signals a fundamental shift in thinking about the brain.

What Busemeyer and co are saying is that the principles of quantum information processing, including the ideas of superposition and interference, lead to better models of the way humans make decisions.

What this idea needs, of course, is some kind of testable hypothesis that differentiates it from classical models. The team hint at this when describing how the principle of superposition applies to thinking about voting habits, when a voter has to choose between two candidates.

According to classical theory, before the vote is cast, the voter is in a mixed state. But Busemeyer and co say that thinking about the voter in a superposition of states is a better model. That kind of thinking ought to lead to some testable predictions. Busemeyer and co are at pains to distance themselves from research that uses quantum mechanics to model the brain in an attempt to understand consciousness. and memory. “We are not following this line,” they say. Instead they keep their work far more abstract.

4.1 Applying Decision Theory to Quantum Events

A two state system, such as a coin, is one of the simplest gaming devices. If we have a player that can utilize quantum moves we can demonstrate how the

expanded space of possible strategies can be turned to advantage. Meyer, in his seminal work on quantum game theory ([10,11]), considered the simple game “penny flip” that consists of the following: Alice prepares a coin in the heads state, Bob, without knowing the state of the coin, can choose to either flip the coin or leave its state unaltered, and Alice, without knowing Bob’s action, can do likewise. Finally, Bob has a second turn at the coin. The coin is now examined and Bob wins if it shows heads. A classical coin clearly gives both players an equal probability of success unless they utilize knowledge of the other’s psychological bias, and such knowledge is beyond analysis by standard game theory ([10, 11, 12]).

To quantize this game, we replace the coin by a two state quantum system such as a spin one-half particle. Now Bob is given the power to make quantum moves while Alice is restricted to classical ones. Can Bob profit from his increased strategic space? Let $|0\rangle$ represent the “heads” state and $|1\rangle$ the “tails” state. Alice initially prepares the system in the $|0\rangle$ state. Bob can proceed by first applying the Hadamard operator,

$$\hat{H} = \frac{1}{\sqrt{2}} \begin{pmatrix} 1 & 1 \\ 1 & -1 \end{pmatrix}$$

Putting the system into the equal superposition of the two states: $(|0\rangle + |1\rangle)/\sqrt{2}$. Now Alice can leave the “coin” alone or interchange the states $|0\rangle$ and $|1\rangle$, but if we suppose this is done without causing the system to decohere either action will leave the system unaltered, a fact that can be exploited by Bob. In his second move he applies the Hadamard operator again resulting in the pure state $|0\rangle$ thus winning the game. Bob utilized a superposition of states and the increased latitude allowed him by the possibility of quantum operators to make Alice’s strategy irrelevant, giving him a certainty of winning.

We shall see later that quantum enhancement often exploits entangled states, but in this case it is just the increased possibilities available to the quantum player

that proved decisive. Du et al has also considered quantum strategies in a simplified card game that do not rely on entanglement ([10, 11]).

5 Solving games using quantum theory

Where a player has a choice of two moves they can be encoded by a single bit. To translate this into the quantum realm we replace the bit by a quantum bit or qubit that can be in a linear superposition of the two states. The basis states $|0\rangle$ and $|1\rangle$ correspond to the classical moves. The players' qubits are initially prepared in some state to be specified later. We suppose that the players have a set of instruments that can manipulate their qubit to apply their strategy without causing decoherence of the quantum state. That is, a pure quantum strategy is a unitary operator acting on the player's qubit. Unitary operations on the pair of qubits can be carried out either before the players' moves, for example to entangle the qubits, or afterwards, for example, to disentangle them or to chose an appropriate basis for measurement. Finally, a measurement in the computational basis $\{|0\rangle, |1\rangle\}$ is made on the resulting state and the payoffs are determined in accordance with the payoff matrix. Knowing the final state prior to the measurement, the expectation values of the payoffs can be calculated. The identity operator \hat{I} corresponds to retaining the initial choice while

$$\hat{H} = i\hat{\sigma}_x \begin{pmatrix} 0 & i \\ i & 0 \end{pmatrix}$$

corresponds to a bit flip. The resulting quantum game should contain the classical one as a subset. We can extend the list of possible quantum actions to include any physically realizable action on a player's qubit that is permitted by quantum mechanics. Some of the actions that have been considered include projective measurement and entanglement with ancillary bits or qubits. A quantum game of the above form is easily realized as a quantum algorithm. Physical simulation of

such an algorithm has already been performed for a quantum prisoners' dilemma in a two qubit nuclear magnetic resonance computer ([13]).

5.1 Military quantum decision theory

In the modern warfare environment, quantum decision theory can contribute enough. Considering the simple example that two opponents exist and every one has just a single move.

In traditional 2×2 games where each player has just a single move, creating a superposition by utilizing a quantum strategy will give the same results as a mixed classical strategy. In order to see non-classical results Eisert et al ([14]) produced entanglement between the players' moves. Keeping in mind that the classical game is to be a subset of the quantum one, Eisert created the protocol in Figure 1 for a quantum game between two players, Alice and Bob. The final state can be computed by

$$|\psi_f\rangle = \hat{J}^\dagger (\hat{A} \otimes \hat{B}) \hat{J} |\psi_i\rangle$$

where $|\psi_i\rangle = |00\rangle$ represents the initial state of the qubits and $|\psi_f\rangle$ the final states, \hat{J} is an operator that entangles the players' qubits, and \hat{A} and \hat{B} represent Alice's and Bob's move, respectively.

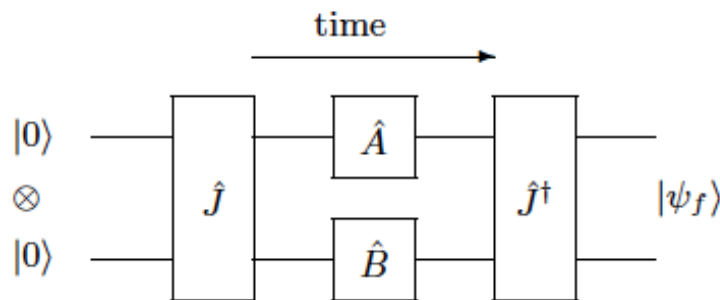

Figure 1

A disentangling gate \hat{J}^\dagger is applied prior to taking a measurement on the final state and the payoff is subsequently computed from the classical payoff matrix.

Since we require the classical game to be a subset of the quantum one, of necessity \hat{J} commutes with the direct product of any pair of classical moves. In the quantum game it is only the expectation value of the players' payoffs that is important. For Alice (Bob) we can write

$$\langle \$ \rangle = P_{00} |\langle \psi f | 00 \rangle|^2 + P_{01} |\langle \psi f | 01 \rangle|^2 + P_{11} |\langle \psi f | 11 \rangle|^2$$

where P_{ij} is the payoff for Alice (Bob) associated with the game outcome ij , $i, j \in \{0,1\}$. If both players apply classical strategies the quantum game provides nothing new. However, if the players adopt quantum strategies the entanglement provides the opportunity for the players' moves to interact in ways with no classical analogue.

A maximally entangling operator \hat{J} , for an $N \times 2$ game, may be written, without loss of generality ([15]), as

$$J = \sqrt{2} (I + i \hat{\sigma}_x).$$

An equivalent form of the entangling operator that permits the degree of entanglement to be controlled by a parameter $\gamma \in [0, \pi/2]$ is

$$\hat{J} = \frac{1}{\sqrt{2}} (I^{\otimes N} + i \widehat{\sigma}_x^{\otimes N})$$

with maximal entanglement corresponding to $\gamma = \pi/2$. The full range of pure quantum strategies are any $\hat{U} \in SU(2)$. We may write

$$\hat{U}(\theta, \alpha, \beta) = \begin{pmatrix} e^{i\alpha} \cos\left(\frac{\theta}{2}\right) & i e^{i\alpha} \sin\left(\frac{\theta}{2}\right) \\ e^{-i\beta} \sin\left(\frac{\theta}{2}\right) & e^{-i\alpha} \cos\left(\frac{\theta}{2}\right) \end{pmatrix}$$

where $\theta \in [0, \pi]$ and $\alpha, \beta \in [-\pi, \pi]$. The strategies $\tilde{U}(\theta) \equiv \hat{U}(\theta, 0, 0)$ are equivalent to classical mixtures between the identity and bit flip operations. When Alice plays $\tilde{U}(\theta A)$ and Bob plays $\tilde{U}(\theta B)$ the payoffs are separable functions of θA and θB and we have nothing more than could be obtained from the classical game by employing mixed strategies. In quantum prisoners' dilemma a player with access to quantum strategies can always do at least as well as a classical player. If cooperation is associated with the $|0\rangle$ state and defection with the $|1\rangle$

state, then the strategy “always cooperate” is $\hat{C} \equiv \tilde{U}(0) = \hat{I}$ and the strategy “always defect” is $\hat{D} \equiv \tilde{U}(\pi) = \hat{F}$. Against a classical Alice playing $\tilde{U}(\theta)$, a quantum Bob can play Eisert’s “miracle” move ([22])

$$\hat{M} = \hat{U}\left(\frac{\pi}{2}, \frac{\pi}{2}, 0\right) = \frac{1}{\sqrt{2}} \begin{pmatrix} 1 & 1 \\ 1 & -1 \end{pmatrix}$$

that yields a payoff of $\$B = 3 + 2\sin\theta$ for Bob while leaving Alice with only $\$A = 1/2(1 - \sin\theta)$. In this case the dilemma is removed in favor of the quantum player. In the partially entangled case, there is a critical value of the entanglement parameter $\gamma = \arcsin(1/\sqrt{5})$, below which the quantum player should revert to the classical dominant strategy \hat{D} to ensure a maximal payoff ([9]). At the critical level of entanglement there is effectively a phase change between the quantum and classical domains of the game ([17, 18]).

In a space of restricted quantum strategies, corresponding to setting $\beta = 0$ in Equation (8), Eisert demonstrated that there was a new NE that yielded a payoff of three to both players, the same as mutual cooperation. This NE has the property of being Pareto optimal. Unfortunately there is no a priori justification to restricting the space of quantum operators to those of with $\beta = 0$.

With the full set of three parameter quantum strategies every strategy has a counter strategy that yields the opponent the maximum payoff of five, while the player is left with the minimum of zero ([13]). This result arises since for any $\hat{A} = \hat{U}(\theta, \alpha, \beta)$ there exists a $\hat{B} = \hat{U}(\theta, \alpha, -\pi/2 - \beta)$ such that,

$$(A \otimes I)\sqrt{2}(|00\rangle + i|11\rangle) = (I \otimes B)\sqrt{2}(|00\rangle + i|11\rangle).$$

That is, on the maximally entangled state any unitary operation that Alice carries out on her qubit is equivalent to a unitary operation that Bob carries out on his. So for any strategy $\hat{U}(\theta, \alpha, \beta)$ chosen by Alice, Bob has the counter $\hat{D} \hat{U}(\theta, -\alpha, \pi/2 - \beta)$, essentially “undoing” Alice’s move and then defecting. Hence there is no equilibrium amongst pure 2 quantum strategies. We still have a (non-unique) NE amongst mixed quantum strategies ([14]). A mixed quantum strategy is the combination of two or more pure quantum strategies using classical probabilities.

This is in contrast to a superposition of pure quantum strategies which simply results in a different pure quantum strategy. The idea is that Alice's strategy consists of choosing the pair of moves

$$\hat{A}_1 = \hat{C} = \begin{pmatrix} 1 & 0 \\ 0 & 1 \end{pmatrix}, \quad \hat{A}_2 = \begin{pmatrix} i & 0 \\ 0 & -i \end{pmatrix}$$

with equal probability, while Bob counters with the corresponding pair of optimal answers

$$\hat{B}_1 = \hat{D} = \begin{pmatrix} i & 0 \\ 0 & i \end{pmatrix}, \quad \hat{A}_2 = \begin{pmatrix} 0 & -1 \\ 1 & 0 \end{pmatrix}$$

with equal probability. The combinations of strategies $\{A_i, B_j\}$ provide Bob with the maximum payoff of five and Alice with the minimum of zero when $i = j$, while the payoffs are reversed when $i \neq j$. The expectation value of the payoffs for each player is then the average of PCD and PDC, or 2.5. There is a continuous set of NE of this type, where Alice and Bob each play a pair of moves with equal probability, namely

$$\begin{aligned} \hat{A}_1 &= \hat{U}(\theta, \alpha, \beta), \quad \hat{A}_2 = \hat{U}(\theta, \pi/2 + \alpha, \pi/2 + \beta), \\ \hat{B}_1 &= \hat{U}(\pi - \theta, \pi/2 + \beta, \alpha), \quad \hat{B}_2 = \hat{U}(\pi - \theta, \pi + \beta, \pi/2 + \alpha) \end{aligned}$$

If other values of the payoffs were chosen in Eq. (1), while still retaining the conditions for a classical prisoners' dilemma ([12]), the average quantum NE payoff may be below (as is the case here) or above that of mutual cooperation ([16]). In the latter case the conflict between the NE and the Pareto optimal outcome has disappeared, while in the former we have at least an improvement over the classical NE result of mutual defection.

The prescription provided by Eisert et al is a general one that can be applied to any 2×2 game, with the generalization to $2 \times n$ games being to use $SU(n)$ operators to represent the players' actions.

This method of quantization is not unique. Another way of achieving similar results is simply to dispense with the entanglement operators and simply hypothesize various initial states, an approach first used by Marinatto and Weber ([17]) and since used by other authors ([25, 22]). The essential difference to

Eisert's scheme is the absence of a disentangling operator. Different games are obtained by assuming different initial states. The classical game (with quantum operators representing mixed classical strategies) is obtained by selecting $|\psi = |00$, while an initial state that is maximally entangled gives rise to the maximum quantum effects. In references [21, 25] the authors restrict the available strategies to probabilistic mixtures of the identity and bit flip operators forcing the players to play a mixed classical strategy. The absence of the \hat{J}^\dagger gate still leads to different results than playing the game entirely classically.

Iqbal has considered ESS in quantum versions of both the prisoners' dilemma and the battle of the sexes ([20]) and concluded that entanglement can be made to produce or eliminate ESSs while retaining the same set of NE. A classical ESS can easily be invaded by a mutant strategy that employs quantum means and that can exploit entanglement. Without the entanglement, the quantum mutants have no advantage. In these models the replicator dynamic takes a "quantum" form ([23]).

6 Discussion

Rationality is the only way in which the concept of 'probability' makes contact with the physical world. But probability is just relative frequency in the limit. If by 'limit' it is meant after an actual infinity of experiments, no-one can actually carry out an actual infinity of experiments. In practice, probabilities are predicted from the relative frequencies of outcomes in finitely many experiments. This isn't automatically correct — probability theory itself predicts a finite probability that it will fail — so it is needed some account of why it's rational to do it. Also, once these "probabilities" exist, what it actually do with them is use them as a guide to expectations about the future. Arguably, if we could do both we'd have a completely satisfactory analysis of probability.

Decision theory is a tool for decision-making under uncertainty. It doesn't introduce a primitive concept of (quantitative) probability at all, incidentally — it just shows that rational decision-making requires us to assign probabilities to events, values to consequences, and then use them together to maximize expected utility. Decision theory provides a framework in which we can understand what is involved in deducing quantitative probabilities for quantum branching, and then shows us that this can be done satisfactorily even when questionable assumptions like addition are abandoned. Furthermore, the relevant links between quantum probability and non-probabilistic facts can then be satisfactorily established. Just as interesting are the implications of quantum theory for decision theory and the general philosophy of probability.

On the technical side, it is noteworthy that the structure axioms required throughout classical decision theory can be very substantially weakened. To be sure, this is only because the mathematical structure of the physical theory (i. e. , QM) in which the decision problem is posed is so rich, but it seems far more satisfactory to have a richly structured physical theory (whose structure is clearly required on directly empirical grounds and in any case is ontologically on a par with any other postulate of physical theorizing) rather than introduce axioms governing rationality which are not self-evident and which fairly clearly are introduced purely to guarantee a representation theorem.

On a more conceptual level, quantum mechanics seems to provide a novel route by which the concept of objective chance can be introduced. An account of how these chances connect with credence is available that is at least as secure as the frequency-based account — indeed, though we do not have a full derivation of the Everett Principal Principle, we have come close. What would be a simple way of seeing how all this is possible: how quantum mechanics can have these consequences for decision theory, and how the derivation of the quantum probability rule was possible in the first place? It's long been recognised that the most fruitful guides to allocation of probability have been frequencies and

symmetries, but the latter has always been somewhat suspect, and it is easy to see why: how are we to choose which symmetries are respected by the chances? Appeal to the symmetries of the physical laws seems the obvious method, but obviously this just begs the question if those laws are probabilistic. Even for deterministic laws, though, the situation is problematic: for if the situation is completely symmetric between two outcomes, how is it that one outcome happens rather than the other? In classical mechanics, for instance, knowledge of the exact microstate of a flipped coin breaks the symmetry of that coin and tells us with certainty which side it will land. The symmetry only enters because we assume the coin's microstate to be distributed randomly with 50% probability of leading to each result, but this introduces probability in advance rather than deriving it from symmetry. In a sense, then, this interpretation reverses the primacy of frequency over symmetry: the frequency of outcomes is an excellent guide to the symmetry of the state being measured, but ultimately it is the symmetries which dictate which events are equiprobable. But inevitably the question will be asked. If the principles of quantum information processing better describe the way humans make decisions, what does that imply about the way the brain works? In general, quantum extension of a standard (classical) game is not unique. Most of the published analyses explore completely positive trace-preserving maps as admissible quantum operations (tactics or strategies). This restriction is conventional but not necessary. The effect noise and decoherence and the use of ancillas and algorithmic aspects in quantum games are the most important areas that invite further research. Quantum game theory should turn out to be an important theoretical tool for investigation of various problems in quantum cryptography and computation, economics, or game theory even if never implemented in real world.

References

- [1] V.I. Yukalov and D. Sornette, Quantum decision theory as quantum theory of measurement.
- [2] J. Von Neumann and O. Morgenstern, *Theory of Games and Economic Behavior*, Princeton University, Princeton, 1953.
- [3] M. Allais, *Econometrica*, 21, (1953), 503.
- [4] W. Edwards, *J. Exp. Psychol.*, **50**, (1955), 201.
- [5] D. Ellsberg, *Quart. J. Econom.*, **75**, (1961), 643.
- [6] J. Von Neumann, *Mathematical Foundations of Quantum Mechanics*, Princeton University, Princeton, 1955.
- [7] P.A. Benioff, *J. Math. Phys.*, **13**, (1972), 908.
- [8] P.A. Benioff, *J. Math. Phys.*, **13**, (1972), 1347.
- [9] A.P. Flitney and D. Abbott, An introduction to quantum game theory.
- [10] D.A. Meyer, Quantum Strategies, *Phys. Rev. Lett.*, **82**, (1999), 1052–1055.
- [11] J. Du, H. Li, X. Xu, M. Shi, X. Zhou and R. Han, *Quantum Strategy without Entanglement*, quant-ph/0010092.
- [12] A prisoners' dilemma is characterized by the payoffs for the row player being in the order $PDC > PCC > PDD > PCD$.
- [13] J. Du, H. Li, X. Xu, M. Shi, J. Wu and R. Han, Experimental Realization of Quantum Games on a Quantum Computer, *Phys. Rev. Lett.*, **88**, (2002), 137902.
- [14] J. Eisert, M. Wilkens and M. Lewenstein, Quantum Games and Quantum Strategies, *Phys. Rev. Lett.*, **83**, (1999), 3077–3088.; 87 (2001) 069802.
- [15] S. C. Benjamin and P. M. Hayden, Multiplayer Quantum Games, *Phys. Rev. A* **64**, (2001), 030301(R).
- [16] S.C. Benjamin and P.M. Hayden, Comment on “Quantum Games and Quantum Strategies, *Phys. Rev. Lett.*, **87**, (2001), 069801.

- [17] L. Marinatto and T. Weber, A Quantum Approach to Static Games of Complete Information, *Phys. Lett. A*, **272**, (2000), 291–303; *277* (2000) 183–184.
- [18] S.C. Benjamin, Comment on “A Quantum Approach to Static Games of Complete Information, *Phys. Lett. A*, **277**, (2000), 180–182.
- [19] A. Iqbal and A. H. Toor, Evolutionarily Stable Strategies in Quantum Games, *Phys. Lett. A*, **280**, (2001), 249–256.
- [20] J. Du, X. Xu, H. Li, X. Zhou and R. Han, Nash Equilibrium in Battle of Sexes, quant-ph/0010050; Remarks on Quantum Battle of Sexes Game, quant-ph/0103004
- [21] A. Iqbal and A. H. Toor, *Equilibria of replicator dynamics in quantum games*, quant-ph/0106135.
- [22] Chuan-Feng Li, Yong-Sheng Zhang, Yun-Feng Huang and Guang-Can Guo, Quantum Strategies of Quantum Measurements, *Phys. Lett. A*, **280**, (2001), 257–260.
- [23] P. Flitney and D. Abbott, Quantum Version of the Monty Hall Problem, *Phys. Rev. A*, **65**, (2002), 062318.
- [24] G.M. D’Ariano, R.D. Gill, M. Keyl, B. Kuemmerer, H. Maassen and R. F. Werner, The Quantum Monty Hall Problem, *Quantum Information and Computing*, **2**, (2002), 355–366.
- [25] A. Iqbal and A.H. Toor, Quantum Mechanics Gives Stability to Nash Equilibrium, *Phys. Rev. A*, **65**, (2002), 022036; Stability of Mixed Nash Equilibrium in Symmetric Quantum Games, quant-ph/0106056.